

Please do not send product to the AWFS® Fair office in advance.

All product entries to be at Las Vegas Convention Center for check-in on July 24, 2023 at the Visionary Showcase Booth

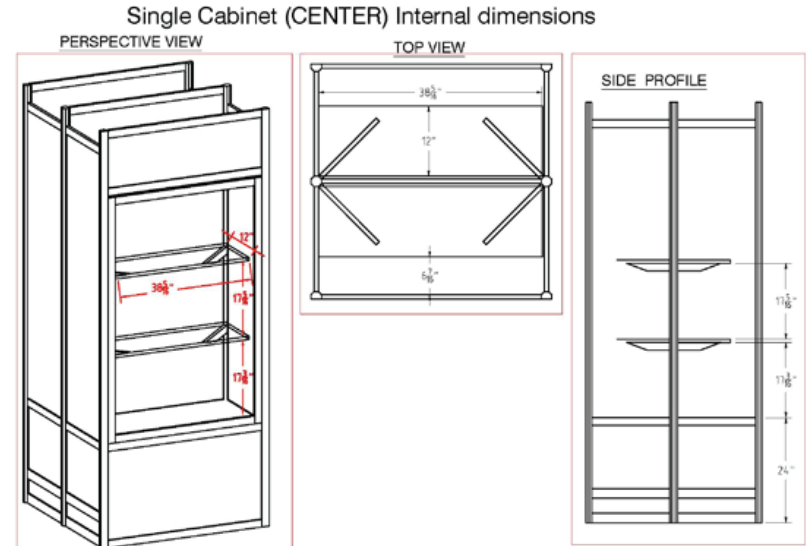

Shelves: $38\frac{5}{16}$ " wide x 12" deep
 Base: 24" high
 From base to bottom shelf: $17\frac{3}{16}$ "
 From first shelf to second shelf: $17\frac{5}{16}$ "

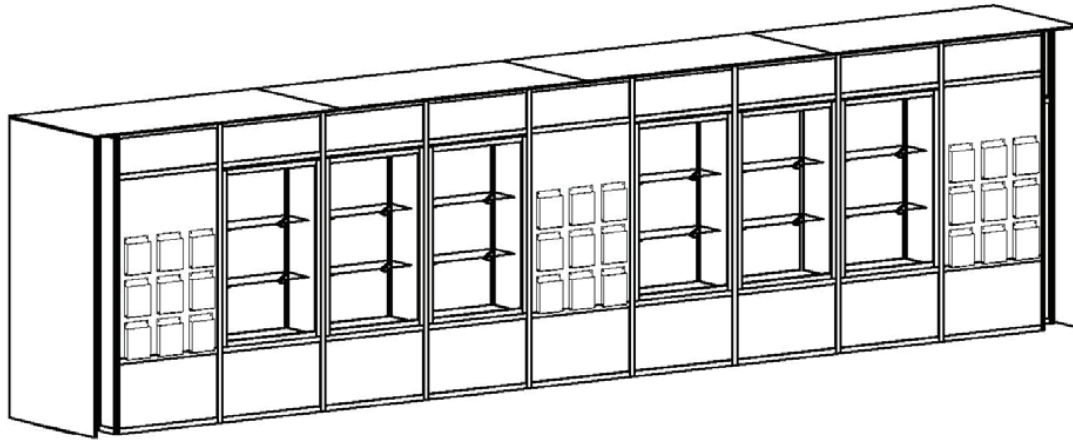
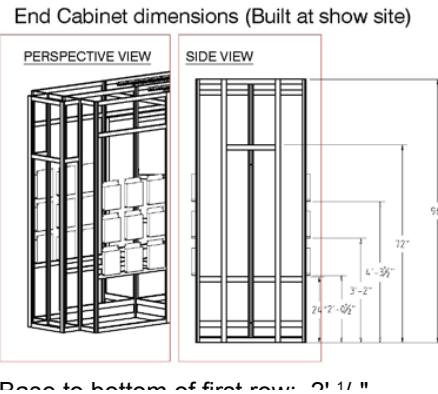
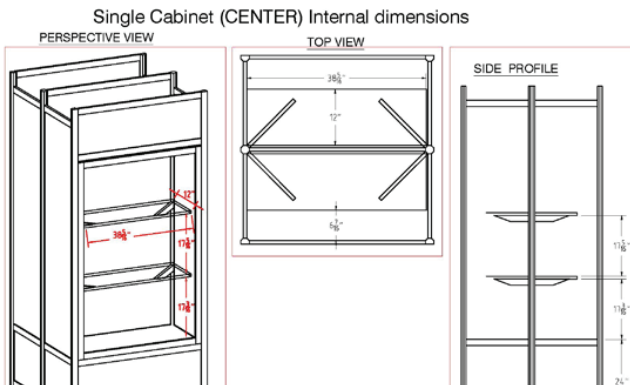

End Cabinet dimensions (Built at show site)

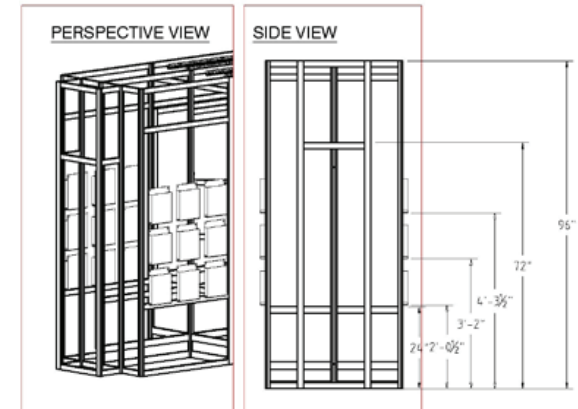

Base to bottom of first row: 2' 1/2"
 Base to bottom of second row: 3' 2"
 Base to bottom of first row: 4' 3 1/2"
 Base to top: 96"

Please contact Angela Hernandez at angela@awfs.org with any questions.

The AWFS® Fair Visionary New Product Awards are prestigious awards recognizing exhibitors for innovation for new-to-market products, which includes any product that has been introduced to the industry since the 2023 AWFS® Fair. All entries that are accepted will have their product featured in the New Product Showcase for the duration of the show regardless of whether or not they are chosen as finalists. This showcase will be located in the a highly visible location and has proven to be one of the Fair's most popular features.

These awards are presented at the Fair, and the recipients will gain favorable media coverage in post-show publications. Add to that, the unlimited opportunities for self-promotion that winning a prestigious award offers, and it's obvious that the potential benefits are well worth the effort of entering and competing for these awards.

In order to enter your new product in the AWFS® Fair Visionary New Product Awards, please fill in the AWFS® Fair Visionary New Product Awards application when it becomes available on this website and be aware that you may enter your product for judging in more than one category. In addition, you will also be able to submit photos, brochures and other product information along with your answers to the New Product questions. Visionary New Product Award winners will be announced on July 27, 2023 at 9:00am. Location will be announced closer to the show. Please do not send product to the AWFS® Fair office in advance.



How to Enter:

Deadline is June 1, 2023

- 1) Complete the AWFS® Fair Visionary New Product Awards application online at visionaryaward23.artcall.org. Website for Visionary entries will be available on March 1, 2023.
- 2) You may enter your product for judging in more than one Main Category. In addition, you will also be able to submit photos brochures, and other product information along with your answers to the New Product questions.

Finalists will be:

- Highlighted by a booth showcase designation as a New Product Finalist at the show.

Winning companies will:

- Be posted on AWFSfair.org, Facebook, Instagram and Twitter directly from the show.
- Be included in a press release announcing the winners.
- Be provided a press release template and logo with media list to promote the win.

For all Visionary New Product Entries

- Entries must be received no later than June 1, 2023 through the Visionary Award website on art call.
- All entries will be guaranteed space in the Visionary Showcase
- Entry payment must be emailed to Angela Hernandez at angela@awfs.org before New Product Awards applications will be accepted. This form may be found on page 28.
- Entry products are to be hand delivered to the Las Vegas Convention Center no later than July 24, 2023 by 3:00pm.
- If your New Product entry is selected as a finalist, you will have the opportunity to present a 15 minute session about your product on the AWFS® Fair Live stage. Time slots will be limited and assigned on a first come first serve basis.

Visionary New Product Showcase and Awards

Deadline:

- This special display area will be created to highlight and preview new products offered by our exhibitors.
- Each entry receives a sign with product name, company, booth number and a brief description of product.
- Use one entry form per new product. You may enter this product in multiple Award Categories if applicable.
- Visit visionaryaward.artcall.org for complete details and to complete the submission process and to submit your product for judging in the Visionary New Product Awards.
- All entries subject to show management approval.
- Entry Fees: \$175 AWFS® Members and \$200 Non-Members per entry per Category.
No extra cost to enter a product in multiple subcategories.

Products larger than 4' in length, 60" in height and/or 20" in depth will not fit in the display cases and will need to have a photo, model or sample submitted in place of the product. (Space restriction may change dependent upon number of entries. Products accepted upon a first-come first-serve basis.)

NAME OF PRODUCT: _____

Company Name: _____

Booth #: _____ Contact Name: _____

Company Address: _____

City: _____ State: _____ Zip: _____

Phone: _____ Fax: _____

Contact Email: _____

PAYMENT INFO

Card holder's name: _____

Billing Address: _____

Card #: _____ Exp date: _____

Signature: _____

Return to: AWFS®Fair, 2400 E Katella Ave, Suite 340, Anaheim, CA 92806

Phone: 800.946.2937; Fax: 323.838.9443

If faxing, be sure to call 323.838.0305 to confirm receipt.

- | | |
|---|--|
| CATEGORY - Check one: | SUB-CATEGORY - Check at least one: |
| <input type="checkbox"/> Components | <input type="checkbox"/> Product Innovation |
| <input type="checkbox"/> Software | <input type="checkbox"/> Productivity |
| <input type="checkbox"/> Raw Materials | <input type="checkbox"/> Green/Environmental |
| <input type="checkbox"/> Machinery under \$50,000 | <input type="checkbox"/> Ergonomics/Safety |
| <input type="checkbox"/> Machinery over \$50,000 | |
| <input type="checkbox"/> Industry 4.0 | |
| <input type="checkbox"/> Power Tools | |
| <input type="checkbox"/> Hardware | |
| <input type="checkbox"/> Tooling | |
| <input type="checkbox"/> Other: _____ | |

No. of entries: _____

Rate \$ = _____ Total: \$ _____

Check enclosed (Payable to AWFS) \$ _____

AWFS[®] *Visionary* Awards



**Please do not send products to the AWFS[®] Fair Office in advance.
All product entries must be at the Las Vegas Convention Center for
check-in no later than 3:00 PM July 24, 2023
at the Visionary Showcase Booth.**